



SEEDING SYSTEMS

DRILLS

PRODUCT RANGE





# Harvest Starts Here

## TILLAGE

The key to a successful harvest is good preparation. Eliminating compaction in the soil to maximise the roots' uptake of moisture and nutrients is vital, as is the preparation of a fine, level, weatherproof seedbed. Whether you operate a conventional tillage or reduced tillage regime, Great Plains Simba offers a wide range of innovative soil loosening, cultivation and consolidation equipment to suit different soil types and operating practices.

## SEEDING

Consistent seed spacing and seed depth and good seed-to-soil contact are vital in your drive to maximise yields. Great Plains Simba drills are designed and built around these fundamental principles. Our range of cultivator and air drills individually combine innovative features, field-proven technology and outstanding build quality to offer first-class seeding solutions in reduced tillage, plough-based and direct drilling regimes.

## PLANTING

The accuracy of the planter is critical to the success of your operation. The planter must be able to precisely place the seed in widely varying residue and soil types. Achieving the optimum seed spacing and seed depth and good seed to soil contact are essential. Every Great Plains Yield-Pro® Planter incorporates all of the key features that enable you to produce outstanding yields season-after-season.

## Seed Drills

Great Plains offers a wide range of innovative seeding equipment including Cultivator Drills, Air Drills and Compact Seeders. Designed and manufactured around proven agronomic principles, our products provide effective solutions that meet your needs for seedbed preparation and high capacity, accurate seed placement. Machines are available in various working widths and to suit reduced tillage, plough-based and direct drilling operations.

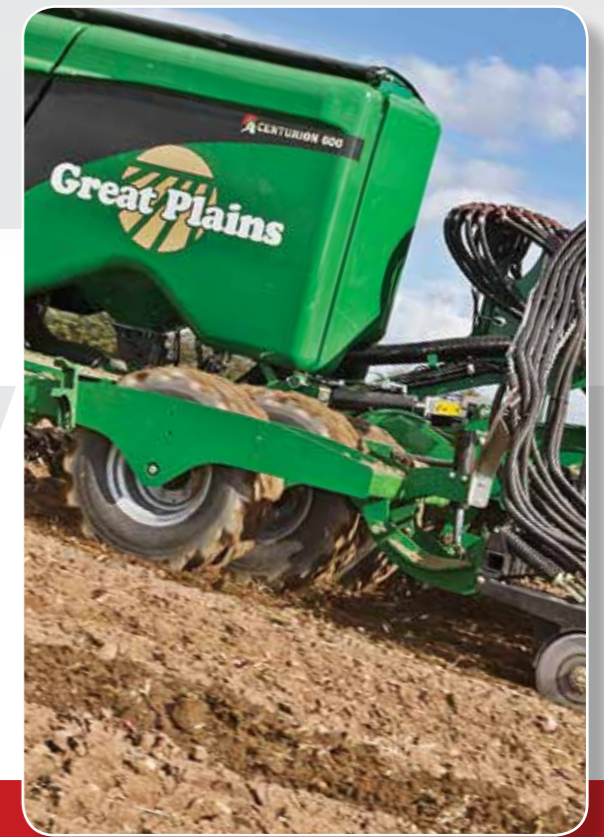

## CONTENTS

02/03	Introduction
04/05	Company Information
06/07/08/09	Centurion Drill
10/11	Spartan 607
12/13	Spartan 907
14/15	V300/300F

## Drills Range



Centurion



Spartan 607



Spartan 907



V300

# Our Mission



Setting the pace through innovation

To Be a Company Where Innovation, Teamwork and a Desire to Improve Combine to:

- Delight Our Customers
- Provide a Rewarding Workplace for our Employees
- Generate Profits for Stability and Growth



*"As agricultural producers, we're all aware of the increasing pressure to produce more with less. The demand for higher efficiency and increasing productivity on the farm has never been greater. At Great Plains, we listen closely to our customers. We work as a team, continually breaking new ground and innovating new products that position your operation to profit in a changing agricultural environment."*

Roy Applequist. Owner, Great Plains Mfg., Inc.

## FROM STRENGTH TO STRENGTH

Founded in 1976 by President and Owner Roy Applequist, Great Plains Manufacturing employs more than 1,400 people in eight Central Kansas communities and Sleaford, England. In addition to its domestic ag equipment division, which manufactures seedbed preparation, nutrient placement, and seeding equipment, Great Plains Manufacturing also includes Great Plains International, Great

Plains Trucking, Great Plains Acceptance Corporation, and its Land Pride Division that manufactures grounds maintenance tools such as mowers, tillers, rotary cutters, and snow removal equipment. The company is one of the largest and fastest growing family-owned "short line" implement companies in the United States and across the world.



 SALINA CAMPUS, SALINA, KS



 ELLSWORTH PLANT  
ELLSWORTH, KS



 TIPTON PLANT  
TIPTON, KS



 SIMBA PLANT  
SLEAFORD, UK



 CORPORATE OFFICE  
SALINA, KS



 PRODUCT DEVELOPMENT  
ASSARIA, KS



 ABILENE PLANT  
ABILENE, KS



 LUCAS PLANT  
LUCAS, KS



 KIPP PLANT  
KIPP, KS



 PRODUCT DEVELOPMENT  
ASSARIA, KS



 ENTERPRISE PLANT  
ENTERPRISE, KS



 TRUCKING DIVISION  
SALINA, KS

# A new standard in productivity and accuracy

Designed to set new standards in productivity, efficiency and operating economy, the Centurion incorporates a host of innovative features alongside proven technologies.



The result is a disc based cultivator drill, ideally suited to reduced tillage and plough-based establishment systems, that delivers superb drilling accuracy, consistent seed placement and reliable depth control across a wide range of soil types and conditions.



MODELS

## Centurion 600

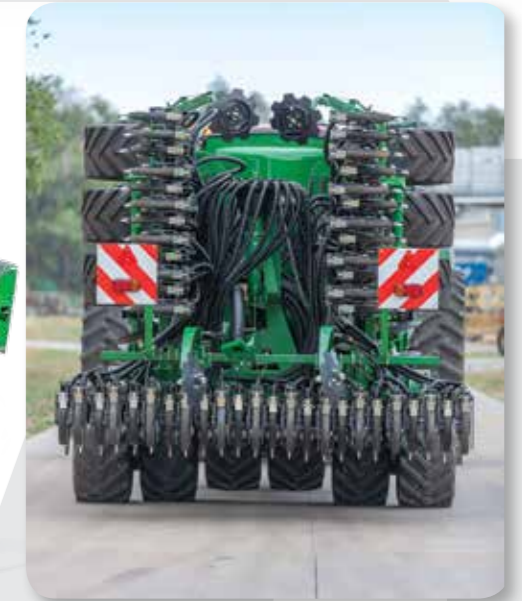

## Features & Benefits

### 1 Cultivation



- Two rows of 460mm scalloped discs, mounted in pairs on maintenance-free hubs. Disc-to-disc spacing is 250mm and 650mm between front and rear gang
- Optional full width levelling board
- Compact following harrow mounted on press wheel

- Track width adjustable pre-emergence markers
- Marker arms with shearbolt protection
- Soil deflectors contain soil within machine width



### 2 Consolidation



- Large diameter, full width tyre packer placed ahead of the drilling coulters features shallow cleated tread pattern for consistent consolidation and improved self-cleaning – no need for scrapers

### 3 Seed Placement



- Large 4100 litre hopper feeds a 125mm diameter metering roller with unique flute design to eliminate 'seed pulsing'
- Precise injection-moulded seed distribution heads with built-in tramline shut-offs and seed flow sensors (optional) accurately deliver seed to each coulters
- Heavy duty coulters arms with down pressure adjustable up to 210kg and easy depth adjustment
- Choice of 167mm or 125mm coulters spacing
- Each coulters incorporates a seed flap to eliminate seed bounce and a rubber cushion which acts as a depth-stop

## Accurate Seed Placement

### 00 Series Drill Opener

Designed for accuracy and well proven across a range of Great Plains seeders, the 00 Series opener is standard on the Centurion drill. It features 36 - 330mm x 4mm offset double disc blades on the 167mm spacing or 48 on the 125mm spacing. The seed tube guides the seed to the bottom of the furrow and the seed is prevented from bouncing out by a seed flap. A rear depth controlling gauge wheel uses a T-handle adjuster with 18 depth settings.

#### Adjustable down pressure

The diagonal spring can be easily adjusted to provide between 40kg and 210kg of down pressure to suit conventional till and reduced tillage. The active down pressure system maintains complete ground contact at all times.

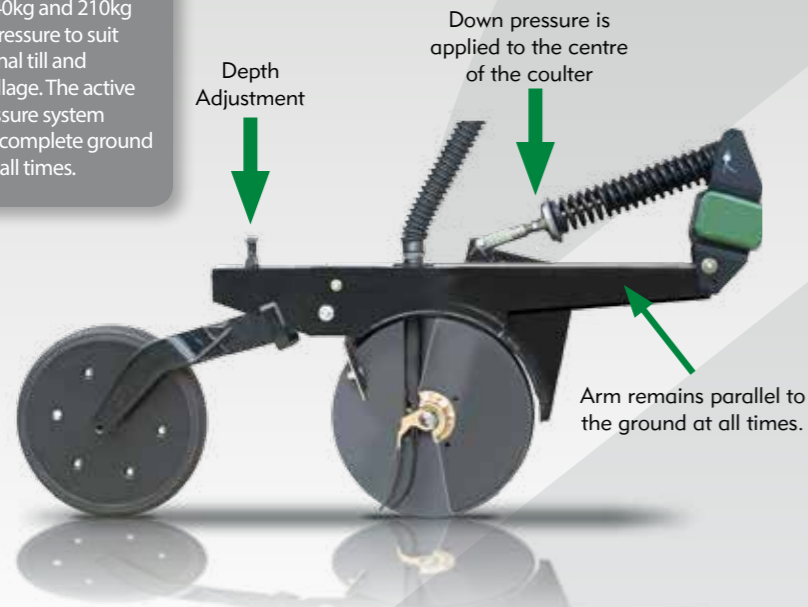

#### Choice of 167mm or 125mm coulters spacing



## Automatic Control of Weight Distribution Across Full Width

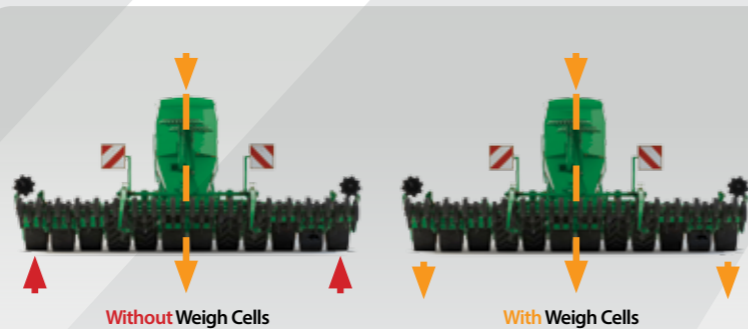

Under the hopper three highly accurate weigh cells (optional), two at the rear and one to the front, automatically adjust the hydraulic down pressure on the wings to maintain consistent working depth across the full width of the machine. As the drill empties, the pressure is reduced. Dampers stop the reading fluctuating when the drill is at work.

## Total Flexibility from Smart Technology

### Advanced ISOBUS System

Data capture and display options include the Müller Elektronik Comfort 10-inch Terminal. The ISOBUS-ready Centurion can also be supplied with the Müller Elektronik Basic control box.



### Helping you to maximise yields

Both the Müller Elektronik displays feature USB ports as standard allowing seed rate maps to be imported directly into the monitor with ease.



Picture for illustration purposes only

### Tramline shut offs and seed blockage sensors

Innovatively designed distribution heads with built-in tramline shut-offs and optional seed flow sensors, accurately deliver seed to each coulters.

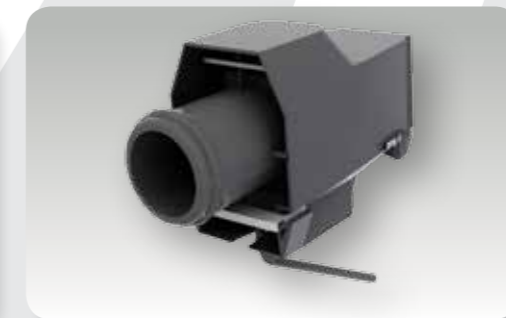

### Highly efficient seed metering

- A 125mm diameter metering roller with unique flute design eliminates 'seed pulsing'
- Roller features an electric motor drive with a wide speed range of 5-120rpm, requiring only 3 roller designs for outputs from 0.5 - 500kg/Ha
- With seed calibration mode selected from the cab, the operator walks to the rear of the drill where, on the flick of a switch, a dedicated pipe delivers the metered amount



## Innovative Tri-Mode Packer System

### Field mode



Allows all tyres to stay in contact with the ground for headland turns

### Transport mode



Gives increased ground clearance (+180mm) for entry and exit of fields by lowering 2 walking axes. This also improves stability on cambered roads.

### Service mode



Further increases lift height (+230mm above transport mode) for easy maintenance access

### TECHNICAL SPECIFICATIONS

Model	Working Width (m)	Transport Width (m)	Weight (kg)	Cultivation Discs	No. of Rows	Coulter Row Spacings (mm)	Hopper Capacity (ltrs)	Power Req (hp)
CENTURION 600	6.0	3.0	7,700	460mm dia (2 Rows)	36 & 48	125 or 167	4,100	225-400

All working widths and weights are approximate depending on machine configuration and settings

## PRECISE GROUND CONTOUR FOLLOWING

### A HYDRAULIC WEIGHT TRANSFER

The Spartan openers can flex up 125mm and down 75mm. They are mounted to a unique frame. The wings of the frame can flex down as much as 10° and up over 15°. Coupled with constant hydraulic down-pressure applied to the wings, this feature allows the drill to precisely follow undulating ground conditions from side to side.

### B FRONT TO BACK FLOTATION

The 2-point parallel linkage connects the centre frame to the cart. The upper linkage is controlled by an adjustable hydraulic cylinder. This allows the machine to flex forward and back 15° hugging the contours of the ground, front to back, over hills and valleys.

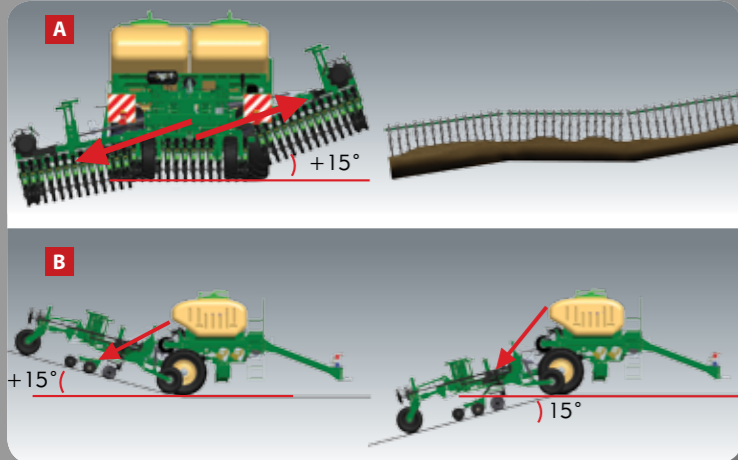

**REAR 'LIFT-ASSIST' TRANSPORT TYRES** - Rear caster wheels help raise the seeder for transport. The weight of the drill is carried by the cart and the rear tyres. In soft conditions the rear wheels will keep the drill from sinking. They can also be raised off the ground in working position.

**A RANGE OF HOPPER OPTIONS** - The Spartan 607 is available with a range of hopper options for seed only and seed/fertiliser applications



5,280 litres single hopper for seed only.



2 x 2,885 litres (5,770 litres total capacity) for seed and fertiliser. Double shoot option available.



1 x 2,885 litres seed and 2 x 760 litres for total of 1,520 litres of liquid fertiliser.

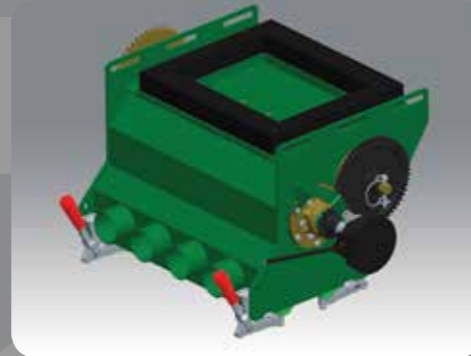

**AIR DRILL METER** - The 607 hopper comes as standard with 4 outlets. The Spartan can seed rape as low as 1.2kg/ha, and wheat as high as 360kg/ha or granular fertiliser as high as 355kg/ha.



With a working width of 6 metres, the Spartan 607 comes with either a single seed-only 5280-litre hopper or two 2885-litre hoppers for seed/fertiliser applications. You can also specify a seed and liquid fertiliser option.

The field-proven openers perform well in all soil types. 380mm x 4mm offset double

disc blades ensure an accurate and well-formed seed slot and a precision planter-style seed tube guides the seed to the bottom of the furrow, eliminating seed bounce.

An infinite ratio gearbox is standard, while an optional variable rate drive enables metering rates to be changed from the tractor cab.

## MODELS SPARTAN 607

Flexible, dependable,  
**highly efficient**

### TECHNICAL SPECIFICATIONS

Model	Working Width (m)	Transport Width (m)	Weight (kg)	No. of Rows	Row Spacing (mm)	Power Req (hp)
SPARTAN 607	6.00	3.00	10,600	40, 32	150, 190	170+

All working widths and weights are approximate depending on machine configuration and settings



**AIR DRILL METER** - The 907 hopper comes as standard with 6 outlets. The Spartan can seed rape as low as 1.2kg/ha, and wheat as high as 360kg/ha or granular fertiliser as high as 355kg/ha.



**FLOATING HITCH** - The floating hitch with its 9 degrees up and down flex allows the seeder to follow the tractor independently over hills and valleys.

**HYDRAULIC WEIGHT TRANSFER** - The openers are mounted to a parallel linkage hydraulic down-pressure system. This applies pre-set consistent down-pressure to all rows and maintains the geometry between the opener and the soil surface.

The 2-point parallel linkage allows the machine to flex forward and back 15° hugging the contours of the ground, front to back, over hills and valleys.



**GROUND CONTOUR FOLLOWING** - The Spartan openers can flex up 125mm and down 75mm. They are mounted to a unique frame. The wings of the frame can flex down as much as 15° and up over 20°. This capability allows the drill to precisely follow undulating ground conditions from side to side.

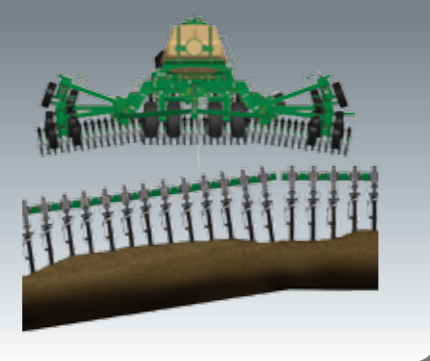

## High accuracy for all soil types

With a working width of 9m, the Spartan 907 is equipped with two 3500-litre hoppers capable of metering seed or granular fertiliser in either hopper without modification. Seed and fertiliser are mixed in the row.

As with the 607 model, an infinite ratio gearbox is standard, while an optional variable rate drive

enables metering rates to be changed from the tractor cab. The openers offer proven performance in all soil types. Offset 380mm x 4mm double disc blades ensure an accurate and well-formed seed slot and a precision planter-style seed tube guides the seed to the bottom of the furrow, eliminating seed bounce.

## MODELS SPARTAN 907



### TECHNICAL SPECIFICATIONS

Model	Working Width (m)	Transport Width (m)	Weight (kg)	No. of Rows	Row Spacing (mm)	Power Req (hp)
SPARTAN 907	9.00	3.00	13,700	60, 48, 36	150, 190, 250	280+

All working widths and weights are approximate depending on machine configuration and settings

## Spartan Air Drills

### SEEDING SYSTEM = ZONE CULTIVATION

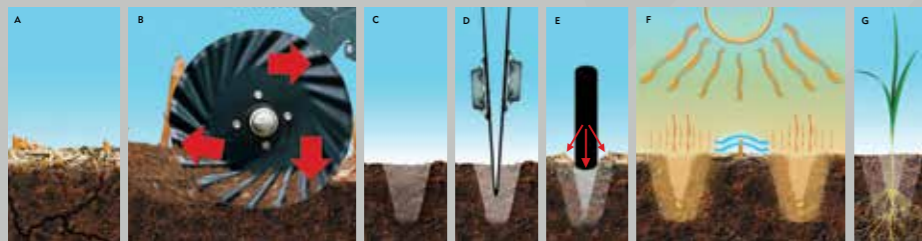

- A:** Pre-cultivated land.
- B:** The Spartan cultivates the soil with the front coulters.
- C:** The ground is worked vertically with straight blades and only in a 3-5cm strip of soil. Straw is cut and moved to the side.
- D:** The double disc openers run in this prepared strip and place the seeds at the bottom of the furrow.
- E:** The closing wheel follows. It is narrow enough to run on the soil and not on the straw ensuring the correct point of depth measurement.
- F:** The black strip warms similarly to a ploughed field, allowing the seeds to germinate and emerge.
- G:** Creates the ideal conditions for healthy growth and high yields



**DRILL OPENER OPTION - KEETON SEED FIRMER** - For seed and liquid fertiliser applications, the opener can be equipped with the Keeton seed firmer and fertiliser tube. Designed for applying N/P/K starter fertiliser only, it dribbles the fertiliser on the bottom of the furrow.



**OPTIONAL FRONT COULTERS** - Optional front coulters prepare a 30-50mm strip of finely cultivated soil and can be set to 250kg of consistent pressure enabling you to direct-seed if required. Choose from the patented Turbo Coulters for high volume chopping of residue or the Fluted Coulters for penetrating very hard soils or heavy clay soils where more trench blow out occurs.

### More standard features



The step-less Infinite Ratio Gearbox allows you to set seed or fertiliser rates of each hopper independently.



The ISOBUS compliant IntelliAG monitor manages seed rate, ground speed, shaft speed, bin levels and hose blockage.



Blockage Monitors on each row notify the operator of any plugging.

**MODELS**  
V300  
V300F



**00 SERIES OPENER** - The standard 00 Series Opener is designed for accuracy and features 330mm x 4mm offset double disc blades. The diagonal spring transfers up to 68 kg of pressure and acts as a suspension when going over rocks to protect the opener and minimise vibrations which negatively impacts seed placement. A simple T-handle with 18 individual adjustments sets opener depth.



**PACKER** - An optional packer is available. This mounts between the 4 drill tires to provide consolidation across the entire width of the seeder.



**CALIBRATION TRAY** - A calibration crank and tray come as standard with the V-300.



**OPTIONAL SMALL SEEDS ATTACHMENT.** - To complement the main seedbox a small seeds attachment is available. It is designed to seed clovers and other small seeds. Customers planning to renovate pastures with this unit can equip this seeder with this attachment and plant two different types of grasses simultaneously.

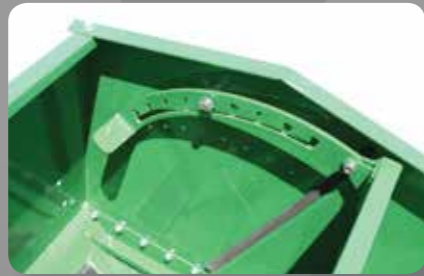

**VARIABLE SEED & FERTILISER BOX** - The V-300F model comes as standard with a 'fertiliser box that is separated by a variable partition with 9 different settings to change the seed and 'fertiliser ratio.

The V-300 is a high capacity mechanical seeder developed to meet requirements of reduced tillage and zero till conditions. It features an optional fertiliser box able to apply over 800kg/ha of granular fertiliser with an adjustable partition separating the seed and fertiliser compartments.

The front of the seeder is equipped with patented turbo coulters that are staggered to prevent plugging. Up to 250 kg of pressure

can be applied to each individual row by transferring weight from the tractor and/or by adding weights to the unit. An optional centre packer provides consolidation and additional floatation.

A center-pivot behind the coulters ensures the 00 Series double disc openers follow in the 20-50mm wide strip cultivated by the coulters. The 330mm diameter double disc opener blades are staggered and mounted to a hydraulically adjustable tube. This allows the tube to float vertically in the field improving the accuracy of seed and fertiliser placement



## The compact, high capacity drill



TECHNICAL SPECIFICATIONS							
Model	Working Width (m)	Transport Width (m)	Base Weight (kg)	No. of Rows	Row Spacing (mm)	Hopper Capacity	Power Req (hp)
V300	3.0	3.0	3,698	19	158	3100L	100
V300F	3.0	3.0	4,188	19	158	Seed: 1222 to 1900L Fert 1649 to 1247L	100

All working widths and weights are approximate depending on machine configuration and settings





# Make Ownership a Reality

Ask your Dealer for details of competitive part-exchange deals and tailored finance options.

DEALER STAMP



**Great Plains Simba,**  
Woodbridge Road, Sleaford,  
Lincolnshire. NG34 7EW. England  
**Tel:** +44 (0)1529 304654 **Fax:** +44 (0)1529 413468  
**E-Mail:** [simba@greatplainsmfg.com](mailto:simba@greatplainsmfg.com)  
**www.greatplainsmfg.co.uk**

**Great Plains International,**  
1525 East North Street,  
Salina, Kansas 67401-5060 USA  
**Tel:** +1-785-823-3276 **Fax:** +1-785-822-6722  
**E-Mail:** [gpi@greatplainsmfg.com](mailto:gpi@greatplainsmfg.com)  
**www.greatplainsint.com**

Simba International Limited, trading as Great Plains Simba, reserves the right to vary specifications with or without notice at such times and in such a manner as deemed appropriate. Major as well as minor changes may be involved. Every effort, however, is made to ensure the accuracy of the particulars contained in this brochure. Consult your Great Plains Simba Dealer for details regarding the specifications of any product. All sales are made by the Distributor or Dealer subject to and with the benefit of the Standard Conditions of Sale and Warranty provided by the Distributor or Dealer, copies of which may be obtained on request.